

Applications of Magnetoresistive Sensors in Navigation Systems

Michael J. Caruso
Honeywell Inc.

ABSTRACT

Most navigation systems today use some type of compass to determine heading direction. Using the earth's magnetic field, electronic compasses based on magnetoresistive (MR) sensors can electrically resolve better than 0.1 degree rotation. Discussion of a simple 8-point compass will be described using MR sensors. Methods for building a one degree compass using MR sensors will also be discussed. Compensation techniques are shown to correct for compass tilt angles and nearby ferrous material disturbances.

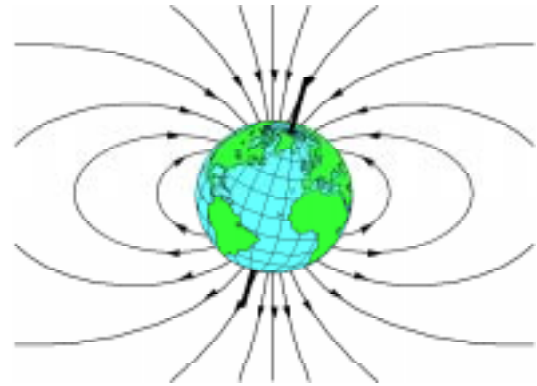

Figure 1 - Earth's Magnetic Field vs. True North

INTRODUCTION

The magnetic compass has been used in navigation for centuries. The inventor of the compass is not known, though evidence suggests that the Chinese were using lodestone—a magnetic iron ore—over 2000 years ago to indicate horizontal directions. It appears that Mediterranean seamen of the 12th century were the first to use a magnetic compass at sea [1]. Today, the balanced needle compass is only a slight variation of this early discovery. Advances in technology have led to the solid state electronic compass based on MR magnetic sensors and acceleration based tilt sensors. Electronic compasses offer many advantages over conventional “needle” type or gimbaled compasses such as: shock and vibration resistance, electronic compensation for stray field effects, and direct interface to electronic navigation systems. Two types of compasses will be discussed in this paper—a basic eight-point compass and a one-degree compass.

EARTH'S MAGNETIC FIELD

The earth's magnetic field intensity is about 0.5 to 0.6 gauss and has a component parallel to the earth's surface that always point toward magnetic north. This is the basis for all magnetic compasses. The key words here are “parallel to the earth's surface” and “magnetic north”.

The earth's magnetic field can be approximated with the dipole model shown in Figure 1. This figure illustrates that the earth's field points down toward north in the northern hemisphere, is horizontal and pointing north at the equator, and point up toward north in the southern hemisphere. In all cases, the direction of the earth's field is always pointing to magnetic north. It is the components of this field that are parallel to the earth's surface that are used to determine compass direction. The angle of the magnetic field to the surface of the earth is called the dip, or inclination, angle (see Figure 2). In the northern hemisphere, the dip angle is roughly 70° down toward the north. Only the X and Y components of the earth's field is used when determining the azimuth, or compass direction. The vertical portion of the earth's magnetic field is ignored.

The term magnetic north refers to the earth's magnetic pole position and differs from true, or geographic, north by about 11.5 degrees. True north is at the earth's rotational axis and is referenced by the meridian lines found on maps. At different locations around the globe magnetic north and true north can differ by ± 25 degrees, or more as shown in Figure 3. This difference is called the declination angle and can be determined from a lookup table based on the geographic location.

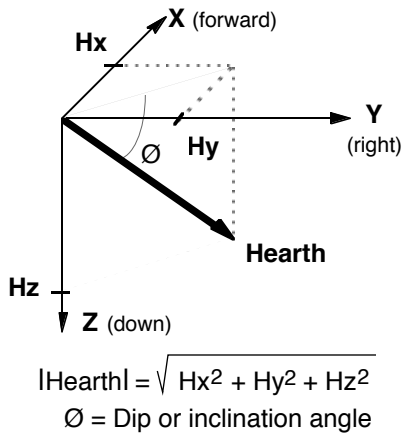

Figure 2 - Earth's Field in X, Y, Z Coordinates

The key to accurately finding a compass heading, or azimuth, is a two step process: 1) determine the Hx and Hy horizontal components of the earth's magnetic field and 2) add or subtract the proper declination angle to correct for true north.

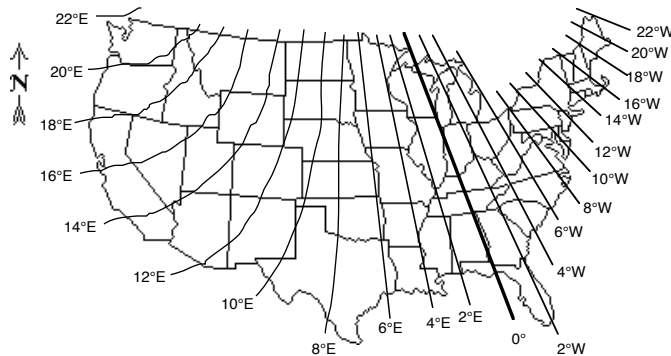

Figure 3 - Declination Angle To Correct For True North

BASICS OF MAGNETIC SENSING

Today, there are several types of electronic compasses to choose from: fluxgate, magnetoresistive, magnetoinductive, and others. A common type of magnetic compass for navigation systems is the fluxgate sensor. The fluxgate sensor consists of a set of coils around a core with excitation circuitry that is capable of measuring magnetic fields with less than 1 milligauss resolution. These sensors provide a low cost means of magnetic field detection; they also tend to be bulky, somewhat fragile, and have a slow response time. Sometimes, fluxgate sensors in motion can have a reading response time of 2-3 seconds. This reading delay may be unacceptable when navigating a high speed vehicle or an unmanned plane.

Another type of magnetic sensor is the magnetoresistive (MR) sensor. This sensor is made up of thin strips of permalloy (NiFe magnetic film) whose electrical resistance varies with a change in applied magnetic field. These sensors have a well defined axis of sensitivity and are mass produced as an integrated circuit. Recent MR sensors show sensitivities below 0.1 milligauss, come in small solid state packages, and have a response time less than 1 microsecond. These MR sensors allow reliable magnetic readings in moving vehicles at rates up to 1,000 times a second.

A magnetoresistive sensor will be used in the remainder of this paper to detect both the sign and magnitude of the earth's field as a voltage output. The sensor will also detect any stray field or field anomaly superimposed onto the earth's field. The magnetic sensor output will have an X, Y, and Z component referenced to the magnetic sensor, or compass, package. For our navigational reference: the X component will be in the forward looking direction, the Y component to the right, and the Z component will be down as shown in Figure 2.

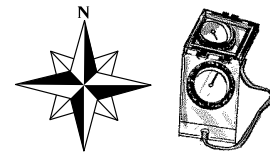

COMPASS DESIGN

There are many forms of compasses used in navigation systems. Two forms will be discussed here that use magnetoresistive magnetic sensors—the eight point compass and the one-degree compass.

EIGHT-POINT COMPASS—A simple eight point compass depicts the cardinal points (N, S, E, W) and the midway points (NE, NW, SE, SW). This type of compass may be used for basic automotive use where the driver needs to know the general direction of travel. For this application, the magnetic sensor can be reduced to a two-axis sensor using only the X and Y axis. An automobile usually travels on a level surface, barring any hills or potholes, so that the X and Y sensors will directly measure the earth's Hx and Hy magnetic fields. The compass can be mounted on the dashboard with the X axis pointing straight ahead and the Y axis to the left. For now, ignore the magnetic effect of the car on the earth's field.

The compass design can be broken into eight regions to indicate the cardinal directions. To analyze the magnetoresistive sensor response, plot the X and Y outputs while the car travels in a circle as indicated in Figure 4. Knowing that the earth's magnetic field is always pointing toward the north, start the analysis with the X axis (and the car) directly pointing north. The X output will be at its maximum value while the Y output

will be zero—since no part of the earth’s field is pointing to the left, or west. As the car turns clockwise toward the east, the X axis will diminish to zero while the Y axis will decrease to its maximum negative value. With the car continuing its clockwise turn to point due south, the X axis will decrease to its most negative value while the Y axis will return to zero. This effect is illustrated in Figure 4 and shows the complete circular cycle for the X and Y axis outputs. The X and Y outputs of the magnetometer can be modeled by the $\cos(\theta)$ and $\sin(\theta)$ functions where θ is the azimuth, referenced to magnetic north.

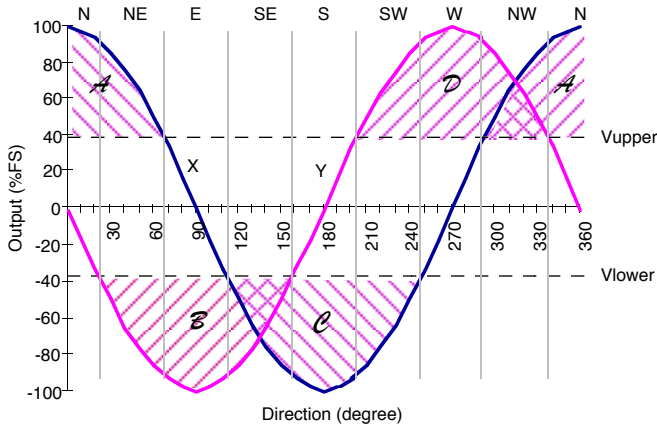

Figure 4 - Magnetic Outputs X And Y For 360° Rotation

The X and Y curves in Figure 4 can be split into eight regions representing the four cardinal and four midway points. A combination of these curves can be formed to represent each region. Two crossover points, Vupper and Vlower, are necessary to distinguish the boundaries of the eight compass direction headings. The crossover points can be determined by knowing the full scale (FS) values for X and Y as:

$$\begin{aligned} V_{upper} &= 100 \cdot \sin(22.5^\circ) (\%FS) = 38 \%FS \quad (1) \\ V_{lower} &= -100 \cdot \sin(22.5^\circ) (\%FS) = -38 \%FS \end{aligned}$$

Voltage comparators can be used to detect Vupper and Vlower levels to divide the X and Y curves into four regions: A, B, C, and D. The eight points of the compass can be determined by combining the A, B, C, and D using Boolean logic gates, four comparators, and a two axis magnetometer as shown in Figure 5. This circuit requires a two axis magnetometer with a signal sensitivity of 1-2 milligauss. Magnetic hysteresis and linearity must be less than 1-2%FS with good repeatability. There are three limitations to consider while using this design: 1) there is no tilt compensation so the compass must be held level, 2) there should be no nearby ferrous material to create magnetic distortions, and 3) the declination angles are difficult to add to this design. These limitations will be addressed in the one-degree compass discussion below.

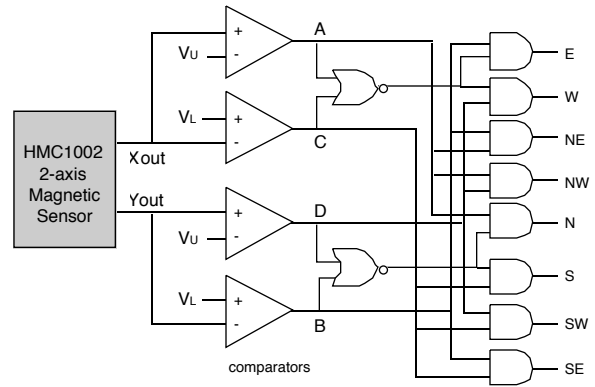

Figure 5 - Eight Point Compass Circuit

ONE-DEGREE COMPASS—Some navigation systems require more than just an eight point compass. For instance, the Global Positioning System (GPS) has led to a sophisticated tracking of vehicle position on video maps with accuracy better than 10 meters. These systems rely on telemetry contact from four satellites, sometimes aided by a system radio tower. It is essential to keep a line of sight with these satellites for position determination. Backup systems are required in cities and tunnels to maintain a course of direction during short blackouts. This is where a more accurate compass can help in GPS based navigation systems. During the loss of GPS signals, knowing the vehicle’s speed and heading direction can maintain proper vehicle tracking. Gyros can be used to maintain direction but a lower cost MR based compass is preferred. For these systems, a compass accuracy of one degree is desirable.

To achieve a one degree accurate compass requires a magnetic sensor that can reliably resolve angular changes to 0.1 degrees. The sensors must also exhibit low hysteresis (<0.05%FS), a high degree of linearity (< 0.5%FS error) and be repeatable. The magnetic fields in the X and Y plane will typically be in the 200 to 300 milligauss range—more at the equator, less at the poles. Using the relationship:

$$\text{Azimuth} = \text{arcTan} (y/x) \quad (2)$$

the required magnetometer resolution can be estimated. To resolve a 0.1° change in a 200milligauss field would require a magnetic sensitivity of better than 0.35 milligauss. Solid state MR sensors are available today that reliably resolve 0.07 milligauss signals giving a five times margin of detection sensitivity.

Using the simple magnetic sensor shown in Figure 6, the azimuth can be calculated by using the X and Y outputs in a horizontal plane. To account for the tangent function being valid over 180° and not allowing the y=0 division calculation, the following equations can be used:

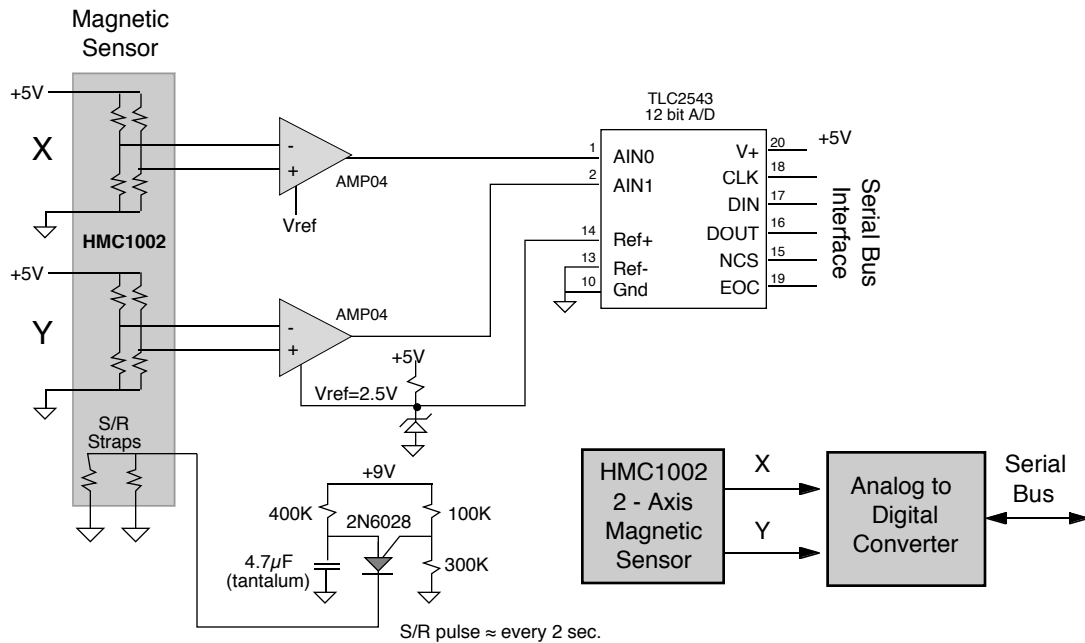

Figure 6 - One Degree Compass System without Tilt Compensation

$$\begin{aligned}
 \text{Azimuth } (x=0, y<0) &= 90.0 & (3) \\
 \text{Azimuth } (x=0, y>0) &= 270.0 \\
 \text{Azimuth } (x<0) &= 180 - [\text{arcTan}(y/x)] * 180/\pi \\
 \text{Azimuth } (x>0, y<0) &= - [\text{arcTan}(y/x)] * 180/\pi \\
 \text{Azimuth } (x>0, y>0) &= 360 - [\text{arcTan}(y/x)] * 180/\pi
 \end{aligned}$$

The set/reset (S/R) circuit shown in Figure 6 is a current pulse generator used to eliminate the effects of past magnetic effects and temperature drift [4]. The serial bus output can readily interface to a low cost microprocessor for azimuth computation. Equations (3) provide continuous azimuth angles from 0° to 360° in the forward direction relative to magnetic north (H_{North}), see Figure 7. In this example, there is no compensation for tilt and nearby ferrous distortion effects on the azimuth.

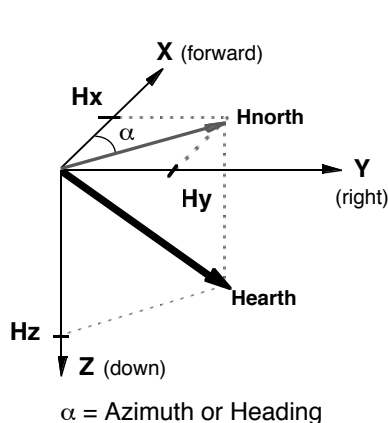

Figure 7 - Azimuth Defined In The X-Y Plane

COMPENSATING FOR TILT—Most often compasses are not confined to a flat and level plane. They are often hand held, attached to an aircraft, or on a vehicle in an uneven terrain. This makes it more difficult to determine the azimuth, or heading direction, since the compass is not always horizontal to the earth's surface. Errors introduced by tilt angles can be quite large depending on the amount of the Dip angle. A typical method for correcting the compass tilt is to use an inclinometer, or tilt sensor, to determine the roll and pitch angles. The terms roll and pitch are commonly used in aviation: ROLL refers to the rotation around the X, or forward direction, and PITCH refers to the rotation around the y, or left-right, direction (see Figure 8).

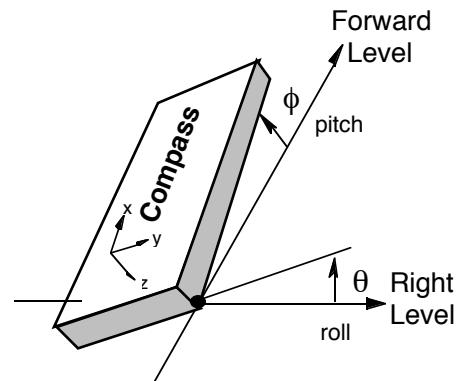

Figure 8 - Compass Tilt Referenced To The Earth's Horizontal Plane

Common liquid filled tilt sensors resemble a glass “thimble” that uses electrodes to monitor the fluid movement as the sensor changes angles. Newer solid state accelerometer tilt sensors are available that measure the earth’s gravitational field by means of an electromechanical circuit [5]. The output of these devices are an electrical signal equivalent to the angle of tilt. During compass assembly, the tilt sensor directions must be carefully aligned with the X,Y,Z magnetic axis. Several manufacturers offer these tilt sensors as stand alone circuit boards that provide the roll and pitch angles as outputs.

To compensate a compass for tilt, knowing the roll and pitch is only half the battle. The magnetometer must now rely on all three magnetic axes (X, Y, Z) so that the earth’s field can be fully rotated back to a horizontal orientation. In Figure 8, a compass is shown with roll (θ) and pitch (ϕ) tilt angles referenced to the right and forward level directions of the observer or vehicle. The X, Y, and Z magnetic readings can be transformed back to the horizontal plane (X_H, Y_H) by applying the rotational equations shown below:

$$X_H = X \cdot \cos(\phi) + Y \cdot \sin(\theta) \cdot \sin(\phi) - Z \cdot \cos(\theta) \cdot \sin(\phi)$$

$$Y_H = Y \cdot \cos(\theta) + Z \cdot \sin(\theta) \tag{4}$$

$$\text{Azimuth} = \text{arcTan}(Y_H / X_H)$$

Once the X and Y magnetic readings are in the horizontal plane, equations (3) can be used to determine the azimuth. For speed in processing the rotational operations, a sine and cosine lookup table can be stored in program memory to minimized computation time.

A block diagram for a tilt compensated compass is shown in Figure 9 with a serial bus interface. After the azimuth is determined, the declination correction can be applied to find true north according to the geographic region of operation.

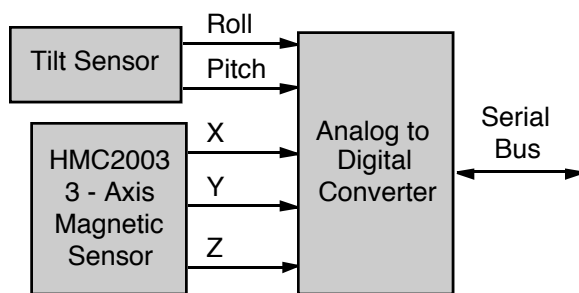

Figure 9- Tilt Compensated Compass System

COMPENSATING FOR NEARBY FERROUS EFFECTS—When a compass is operating in a open area in the absence of any ferrous metals there is no distortion effects on the earth’s magnetic field. In reality, though, compasses are mounted in vehicles, aircraft, and platforms that most likely have ferrous materials nearby. The effects of ferrous metals (iron, nickel, steel, cobalt) will distort, or bend, the earth’s field which will alter the compass heading. These effects can be thought of as a magnetic field that is added to the earth’s field. If the compass is securely mounted in the vehicle, the ferrous effects can be accounted for and removed from the magnetic readings.

Figure 10 illustrates the X and Y magnetic readings when the compass is turning around in a circle in a horizontal plane. In this example, there is no ferrous interference with the earth’s field. The readings are taken from Honeywell’s HMR2300 Smart Digital Magnetometer where each count represents 67 microgauss. The earth’s field magnitude in the X and Y plane reads 2800 counts which is approximately 190 milligauss. When the X and Y readings are plotted with each other they form a circle centered about the 0,0 point. An azimuth can be determined for each reading using equations (3) as show in Figure 10. This plot shows a sine and cosine output response for the X and Y directions during rotation.

If the magnetometer is mounted in a car, the effect of the engine and car body would distort the earth’s magnetic field. Driving the car in a circle would produce the curves shown in Figure 11. Note here that the X,Y plot is not a circle (slightly ellipsoid) and that it is offset from the 0,0 point by -480 and -795 counts. This offset and ellipsoid effect are a result of the fixed distortion of the car on the earth’s magnetic field. This distortion can be determined systematically and applied to subsequent X,Y readings to eliminated the effects of the car.

To compensate for the vehicle’s distortion, two scale factors X_{sf} and Y_{sf} can be determined to change the ellipsoid response to a circle. Offset values X_{off} and Y_{off} can then be calculated to center the circle around the 0,0 origin. The X,Y values used to compute the azimuth when compensating for the vehicle’s distortion are:

$$X_{value} = X_{sf} * X_{reading} + X_{off} \tag{5}$$

$$Y_{value} = Y_{sf} * Y_{reading} + Y_{off}$$

Here, the scale factors X_{sf} and Y_{sf} scale each reading to change the ellipsoid to a circle and X_{off} and Y_{off} values shift the center back to the 0,0 origin. The result of this compensation is shown in Figure 12 and should be compared to the ‘no interference’ curves in Figure 10.

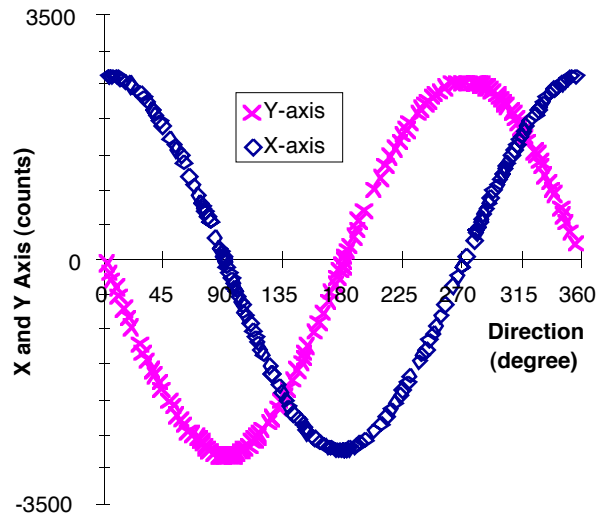
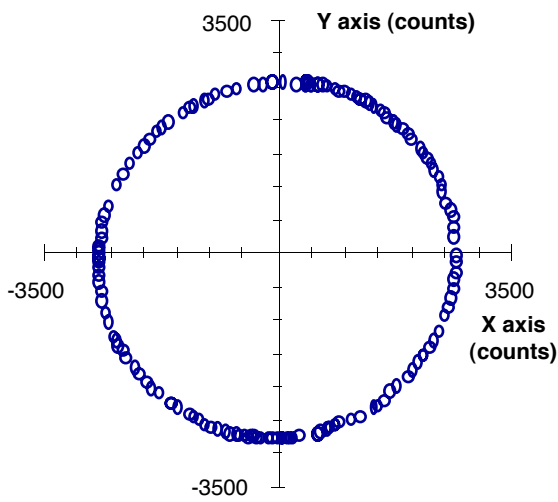

Figure 10 - No Interference Of Magnetometer Readings For 360° Rotation In Level Plane

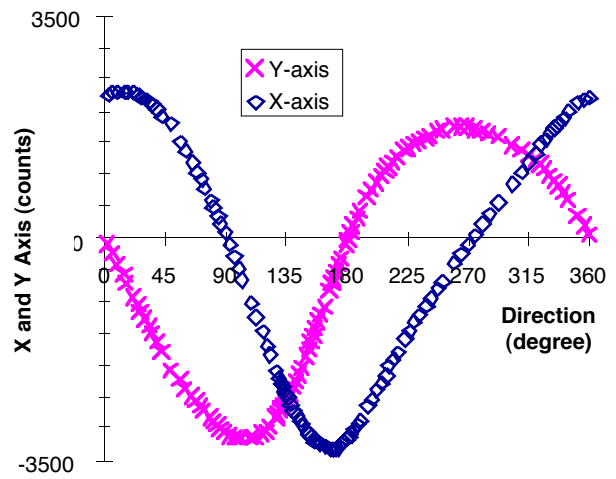
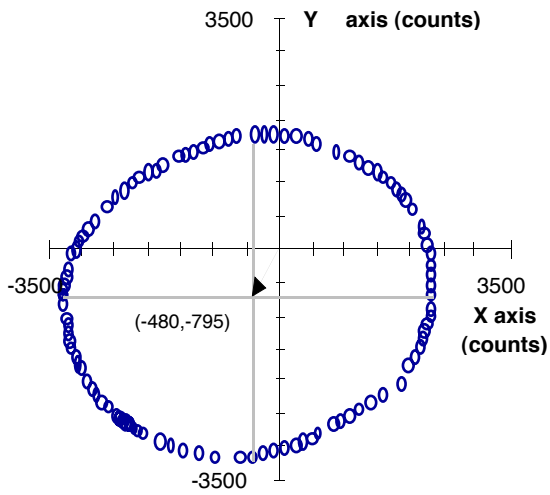

Figure 11 - Car Engine/Body Interference Of Magnetometer Readings For 360° Rotation In Level Plane

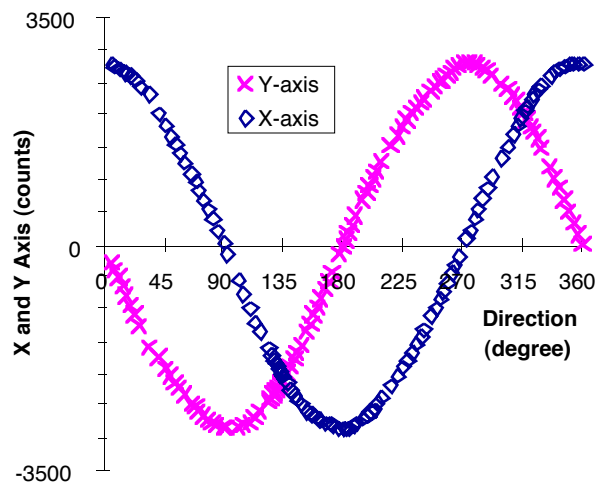
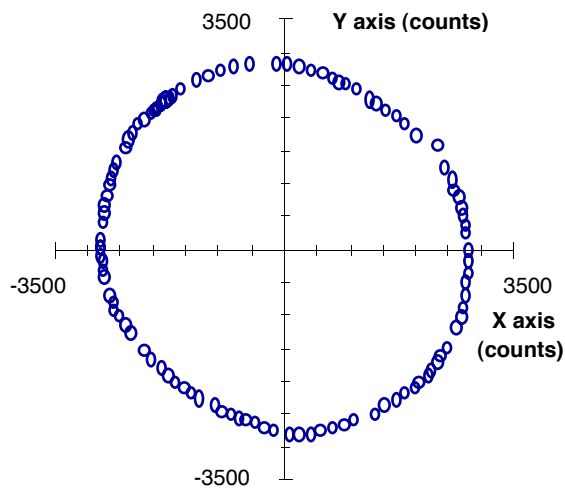

Figure 12 - Car Engine/Body Compensation Of Magnetometer Readings For 360° Rotation In Level Plane

A simple calibration method can be used to determine the offset and scale factor values:

- Mount the compass in the car and drive the car in a circle on a horizontal surface.
- Find the maximum and minimum values of the X and Y magnetic readings.
- Using these four values determine the X and Y scale factors (Xsf, Ysf) and the zero offset values (Xoff, Yoff).

$$Xsf = 1 \text{ or } (Y_{max} - Y_{min}) / (X_{max} - X_{min}) \quad (6)$$

whichever is greater

$$Ysf = 1 \text{ or } (X_{max} - X_{min}) / (Y_{max} - Y_{min})$$

whichever is greater

$$Xoff = [(X_{max} - X_{min})/2 - X_{max}] * Xsf \quad (7)$$

$$Yoff = [(Y_{max} - Y_{min})/2 - Y_{max}] * Ysf$$

The following example will show how the compensation values are determined. A compass is mounted in a car that has traveled a circle in a vacant parking lot. The magnetic X and Y counts (15,000 counts=1 gauss) from the magnetometer are scanned and the minimum and maximum readings are:

$$X_{min} = -3298 \quad X_{max} = 2338$$

$$Y_{min} = -3147 \quad Y_{max} = 1763$$

Set the X scale factor (Xsf) to one since $(Y_{max} - Y_{min}) / (X_{max} - X_{min}) < 1$, according to equation (5). Next, determine the Y scale factor (Ysf) by dividing the X reading span by the Y reading span.

$$Xsf = 1$$

$$Ysf = (X_{max} - X_{min}) / (Y_{max} - Y_{min}) = 1.15$$

Calculate the offset correction values by taking one-half the difference of the max. minus min. readings and apply the scale factors, Xsf and Ysf.

$$Xoff = [(X_{max} - X_{min})/2 - X_{max}] * Xsf = 480$$

$$Yoff = [(Y_{max} - Y_{min})/2 - Y_{max}] * Ysf = 795$$

Store these values and apply them to every tilt compensated reading— X_H and Y_H . The Xvalue and Yvalue numbers used in the azimuth calculations, equations (3), to determine compass heading are:

$$Xvalue = X_H + 480$$

$$Yvalue = 1.15 * Y_H + 795$$

CONCLUSION

Compass headings are determined from the earth's magnetic fields in a horizontal plane. In a compass system each magnetometer reading must first be corrected for tilt. Then each reading must be compensated for the effects of nearby ferrous materials. Once the compass reading is tilt compensated and nearby ferrous material corrected, the declination angle should be applied to adjust magnetic north to true north.

Magnetoresistive sensors provide a solid state solution for building compass navigation systems. Their high sensitivity and good repeatability, along with small size, results in a high accuracy and easy to integrate magnetic sensor. There are many other techniques than the ones shown here for tilt and ferrous distortion compensation. The method for compensation depends on the application requirements: accuracy, resolution, speed, size, and cost.

REFERENCES

[1] Grant, George A., and Klinkert, John, The Ship's Compass, 2d ed. (1970).

[2] Barber, G.W., and Aarott, A.S., History and Magnetics of Compass Adjusting, IEEE Trans. Magn. Nov. 1988.

[3] Olson, Gregory J., et al, Nongimbaled Solid-State Compass, Solid-State Sensor and Actuator Workshop, June, 1994.

[4] Set/Reset Pulse Circuits for Magnetic Sensors, Honeywell Applications Note, AN-201.

[5] A Dual Axis Tilt Sensor Based on Micromachined Accelerometers, Mike Horton, Charles Kitchin, Sensors Magazine, April, 1996.

Unit conversion from SI to Gaussian:

$$1 \text{ Tesla} = 10^4 \text{ gauss} = 10^9 \text{ gamma} = 7.96 \times 10^5 \text{ A/m}$$

$$1 \text{ nTesla} = 10 \mu\text{gauss} = 1 \text{ gamma} = 7.96 \times 10^{-4} \text{ A/m}$$

Honeywell

Solid State Electronics Center

Honeywell Inc.

12001 State Highway 55

Plymouth, MN 55441 2-98 900212

Helping You Control Your World

